

**bobo chic**  
PARIS

**NOTICE DE MONTAGE**  
ASSEMBLING INSTRUCTIONS  
**MANUAL DE MONTAJE**  
INSTRUÇÕES DE INSTALAÇÃO  
**MONTAGEANLEITUNG**  
ISTRUZIONI DI MONTAGGIO

# ACHILLE

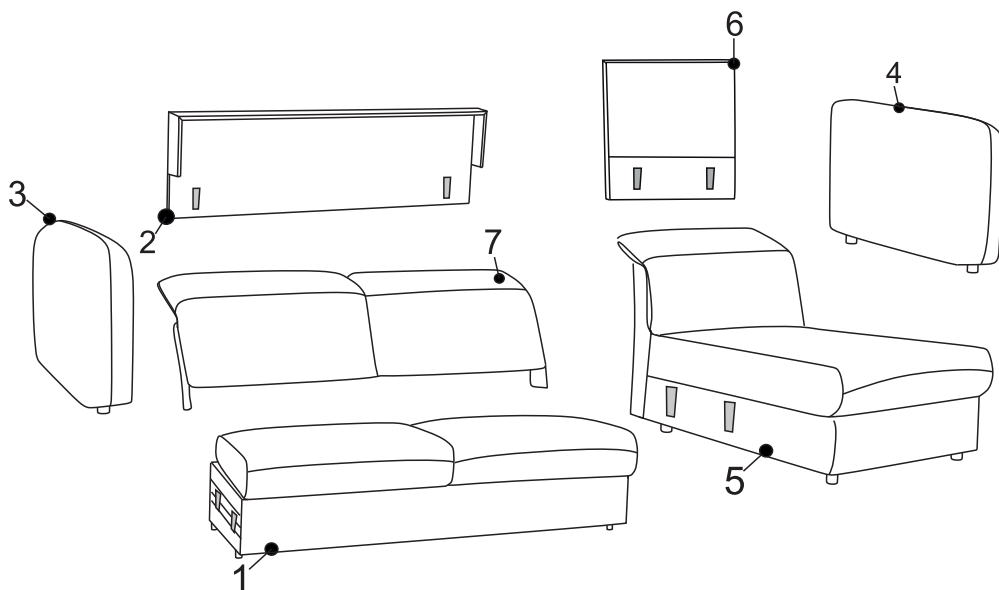
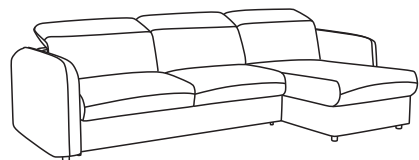

**A x 4** **B x 1** **C x 4** **D x 2** **E x 2** **F x 4** **G x 4**

M8 x 20

5"

M6 x 35

M6 x 45



**Avant d'installer le canapé d'angle veuillez choisir le côté**

Before starting the assembly, choose furniture option

**Antes de iniciar el montaje, elige la opción de mobiliario**

Antes de iniciar a montagem, escolha a opção de mobiliário

**Vor der montage wählen sie bitte die seite**

Prima di iniziare il montaggio, scegli l'opzione mobili

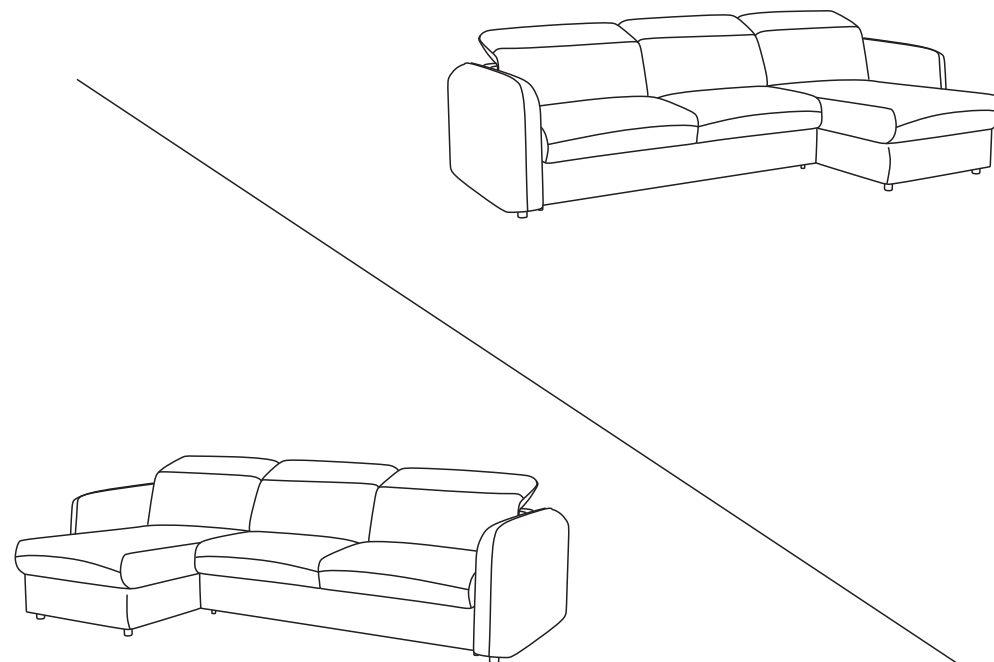

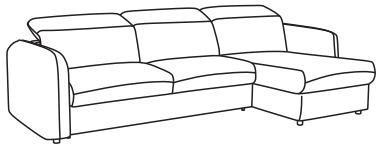

I

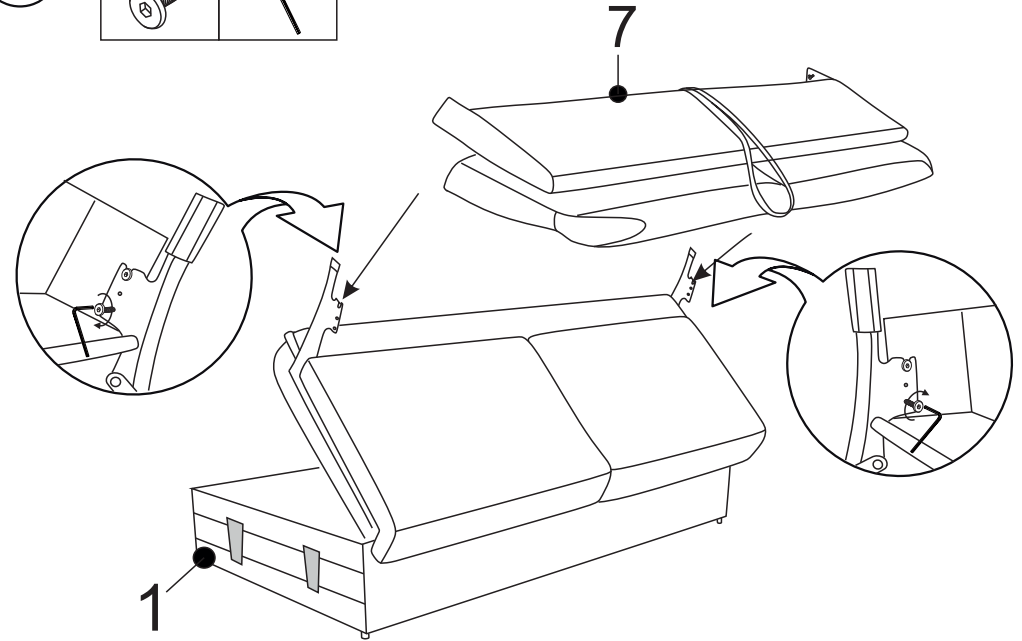
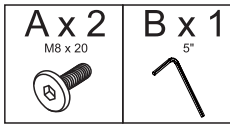
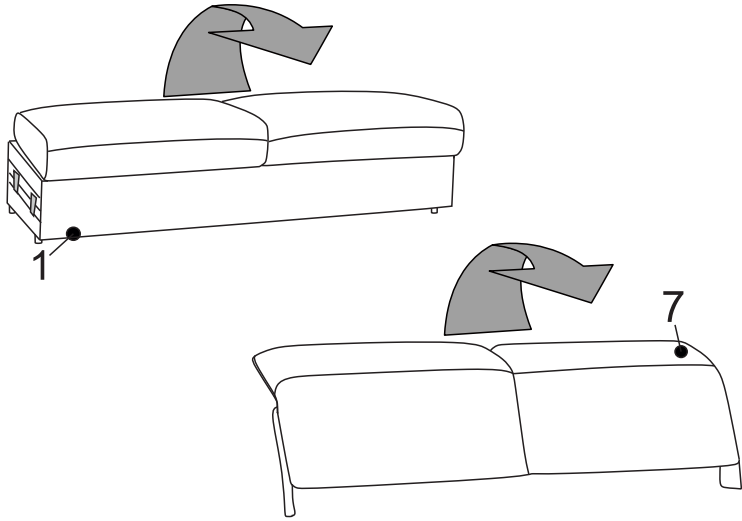

II

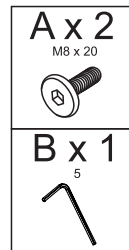
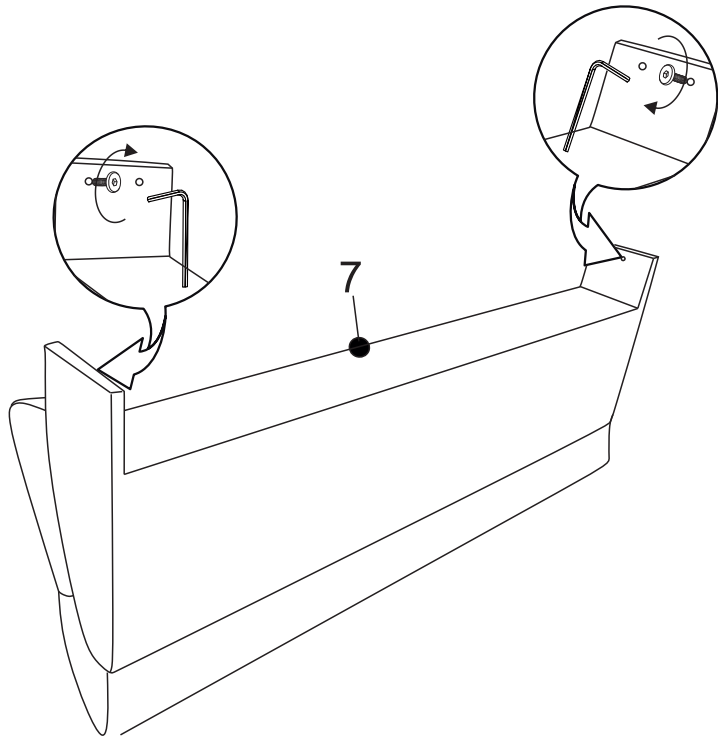

IV

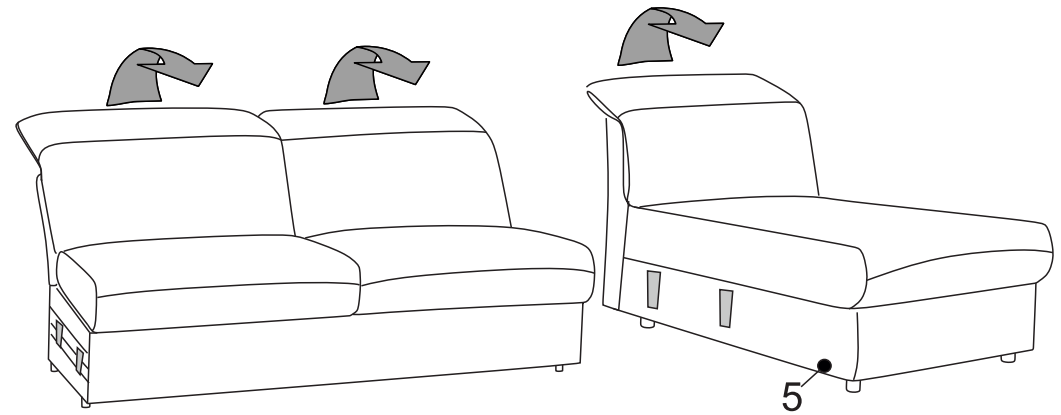

V

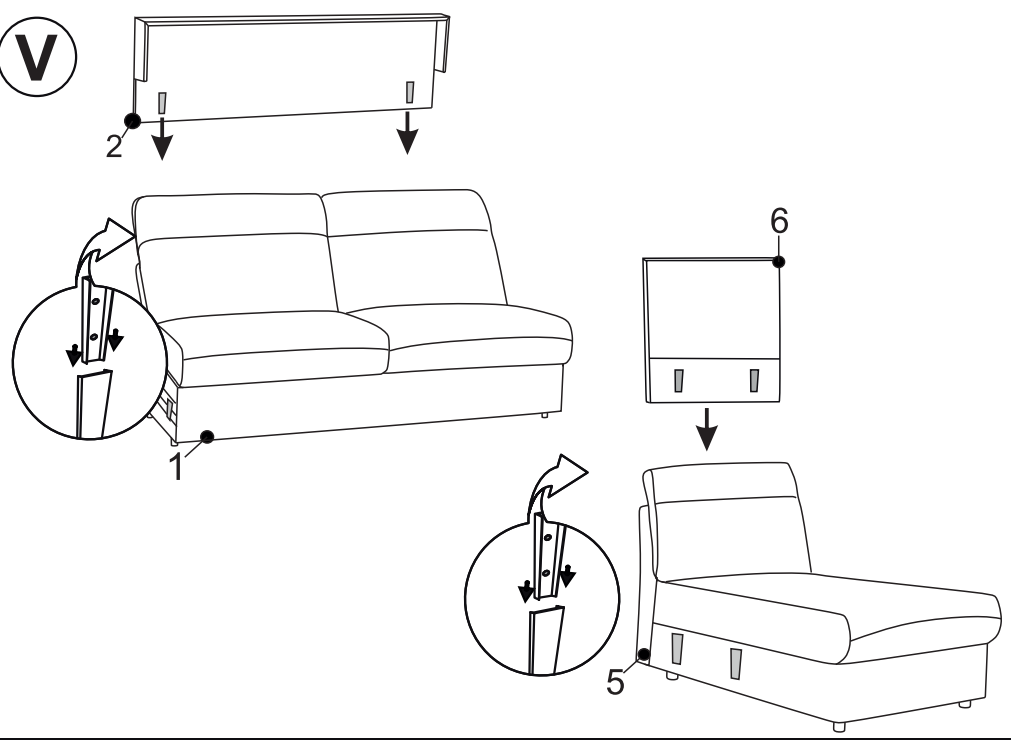

VII

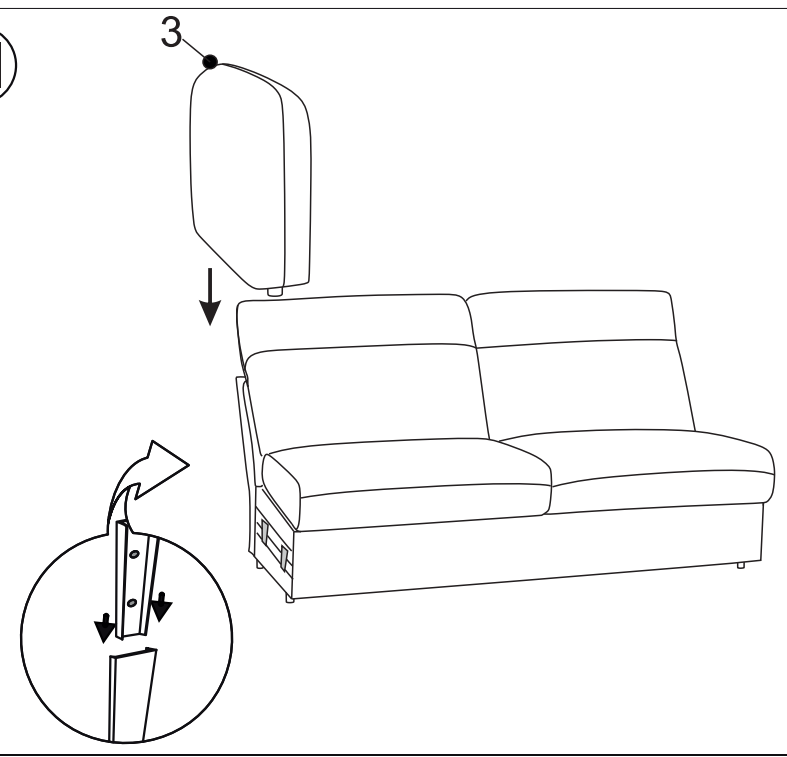

VI

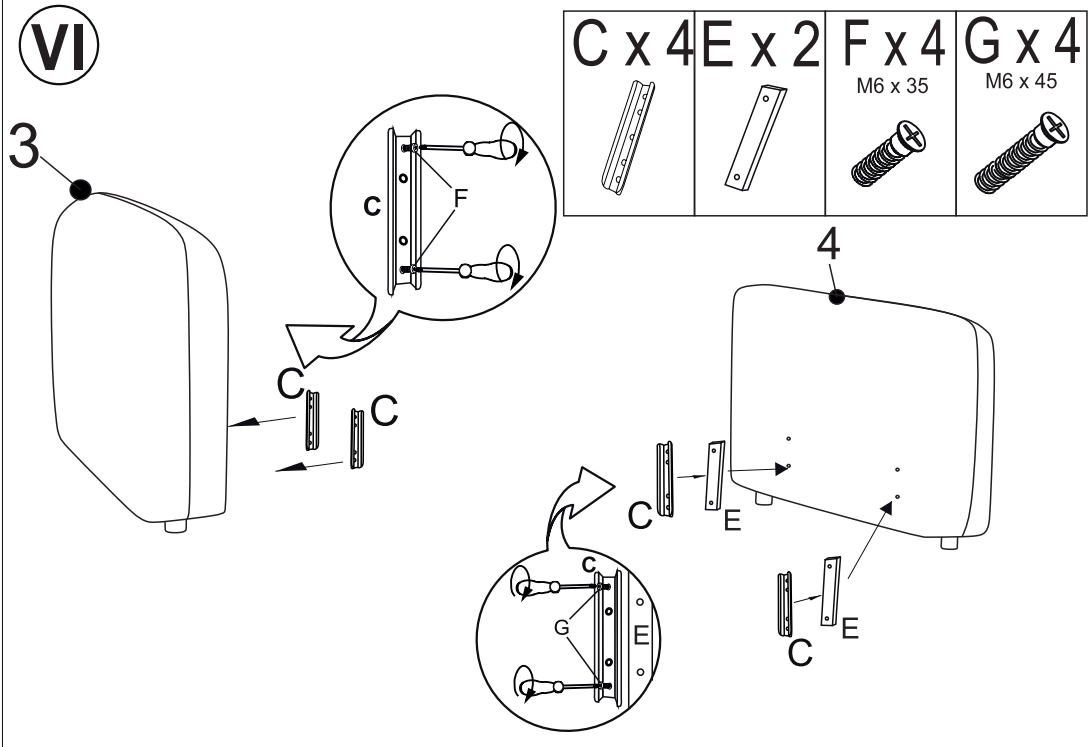

VIII

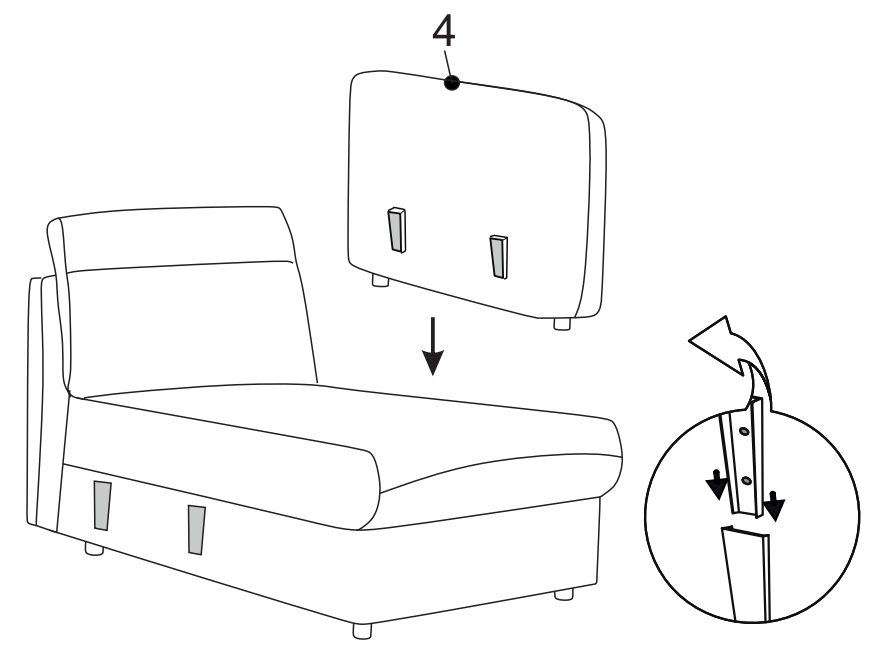

IX

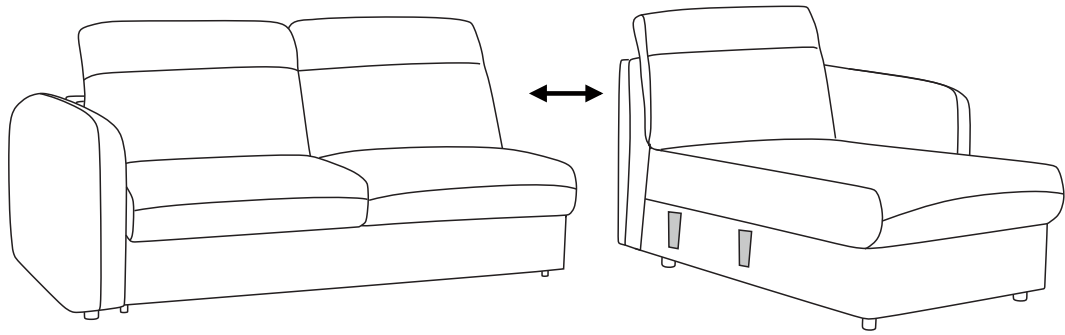

XI

D x 2

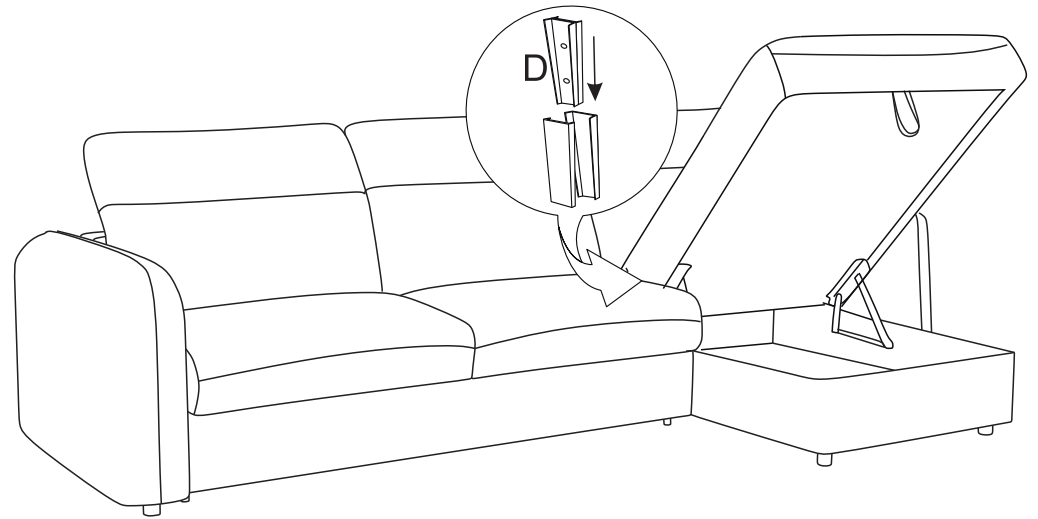

X

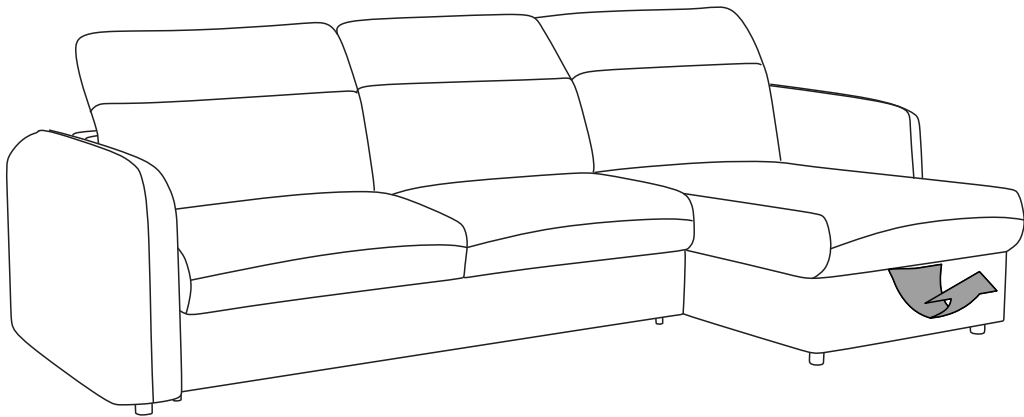

XII

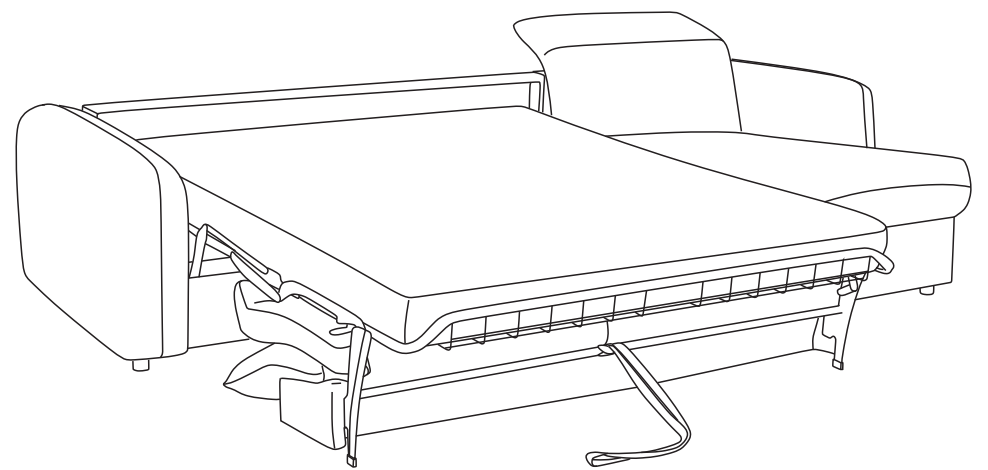



I

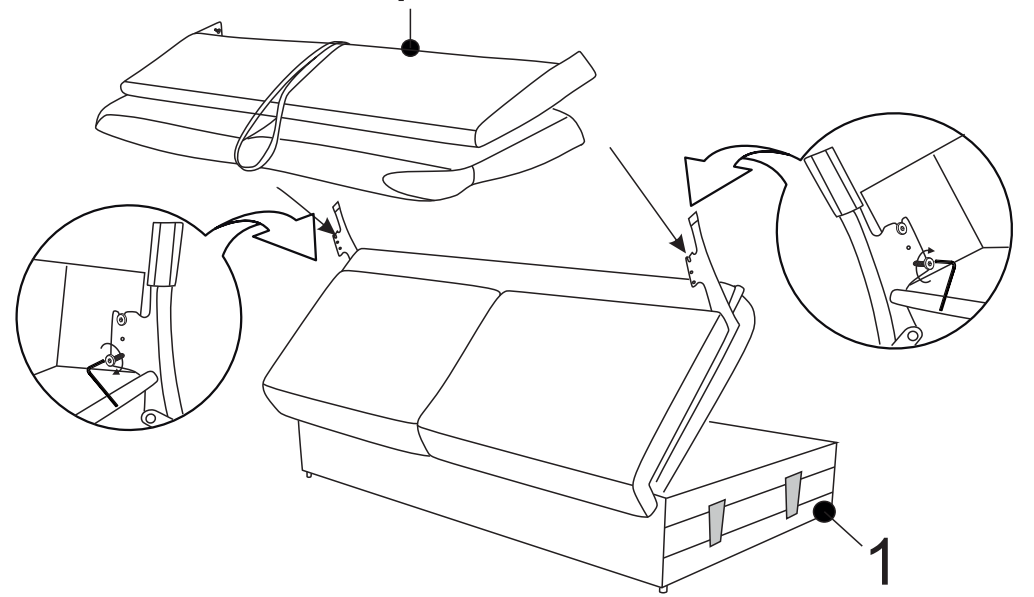
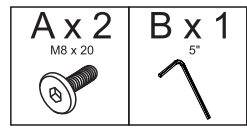
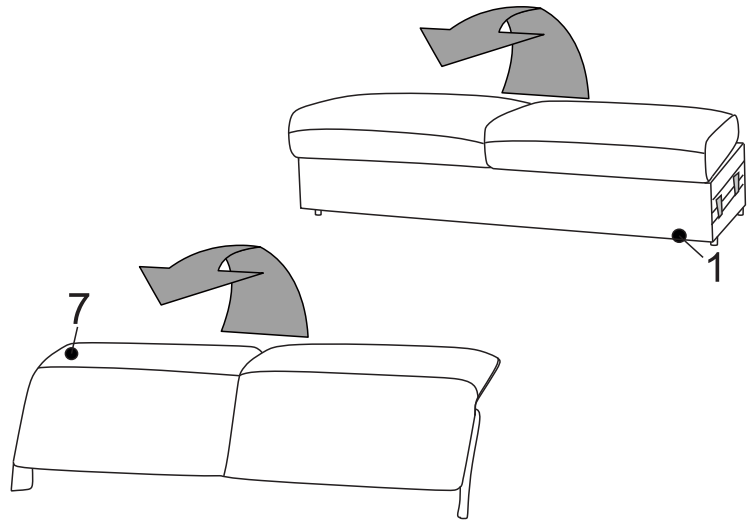

II

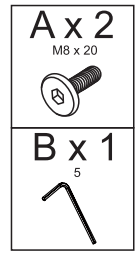
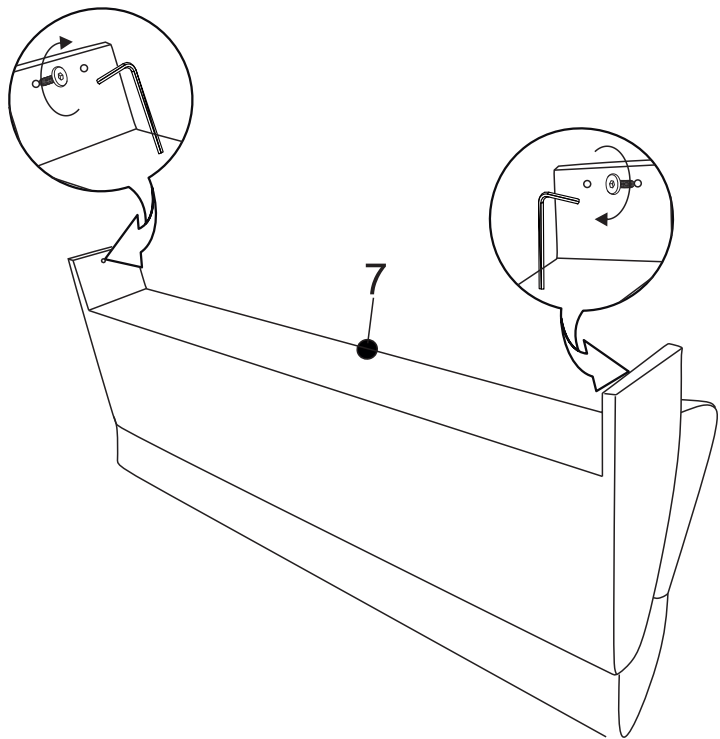

IV

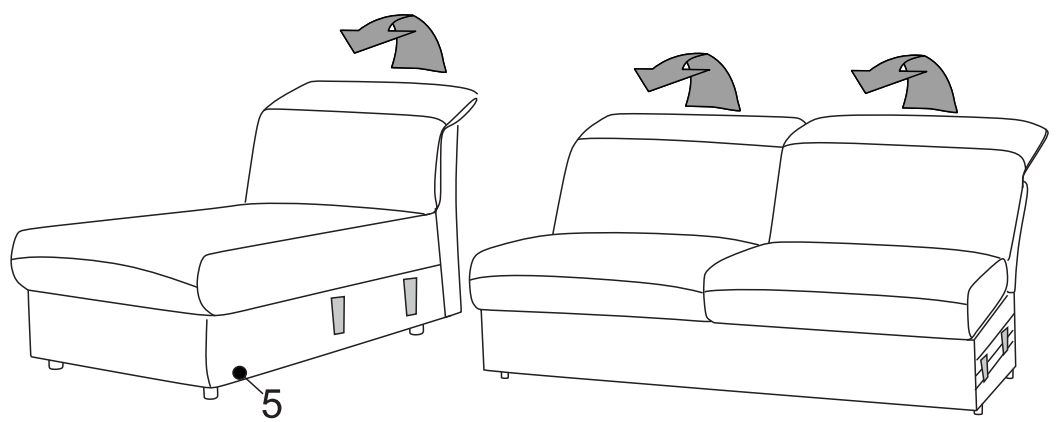

V

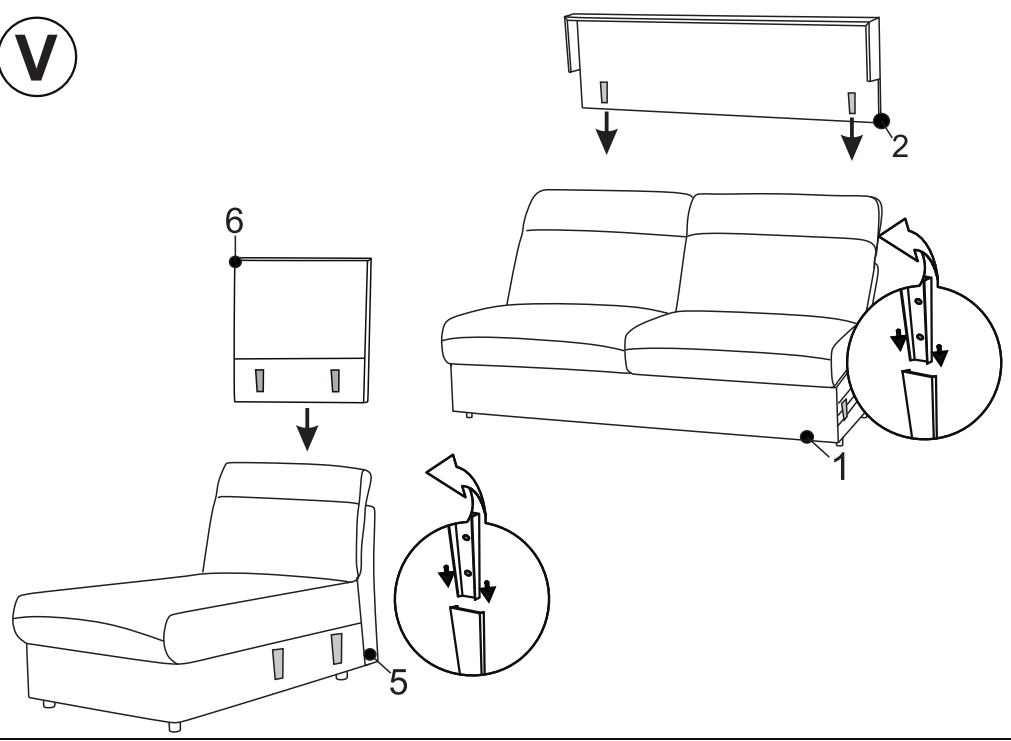

VII

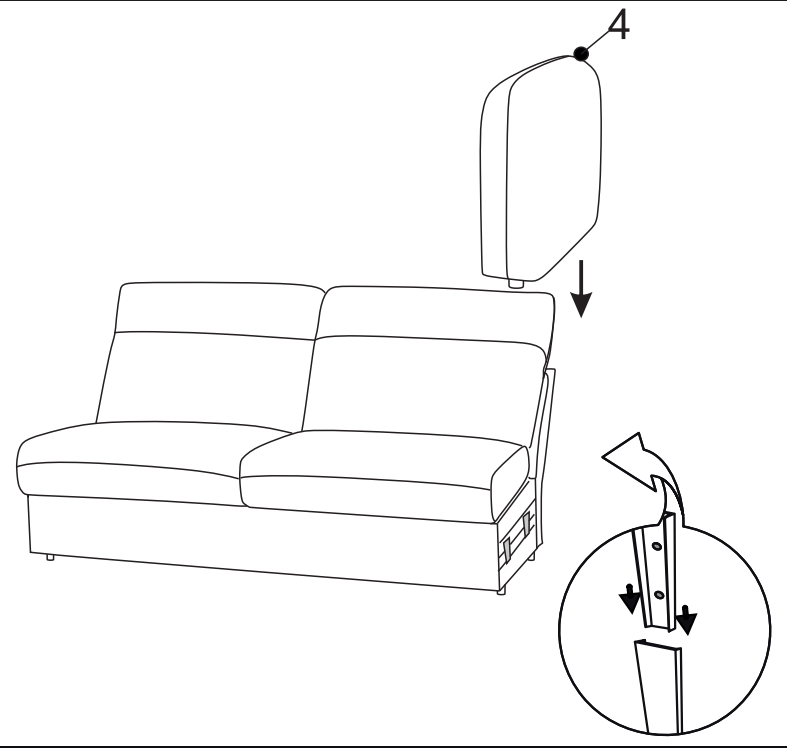

VI

- |              |              |              |              |
|--------------|--------------|--------------|--------------|
| <b>C x 4</b> | <b>E x 2</b> | <b>F x 4</b> | <b>G x 4</b> |
|              |              |              |              |
|              |              | M6 x 35      | M6 x 45      |

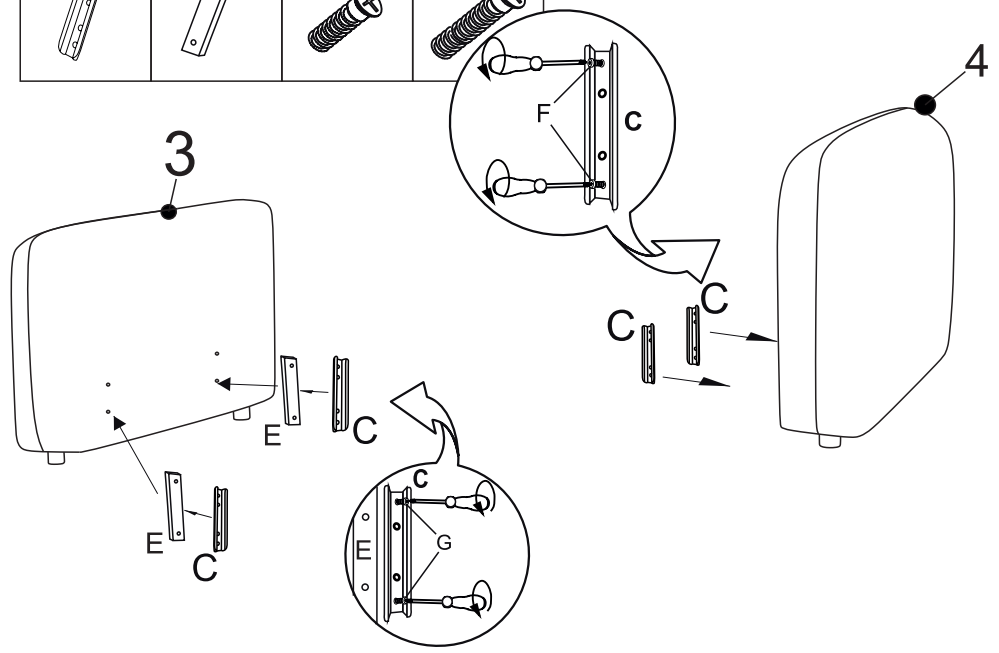

VIII

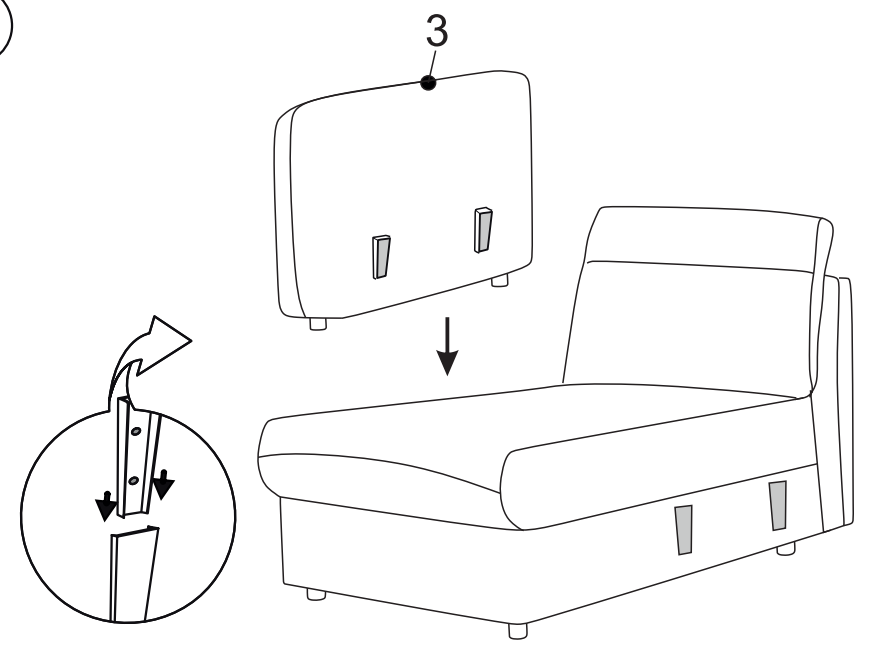

IX

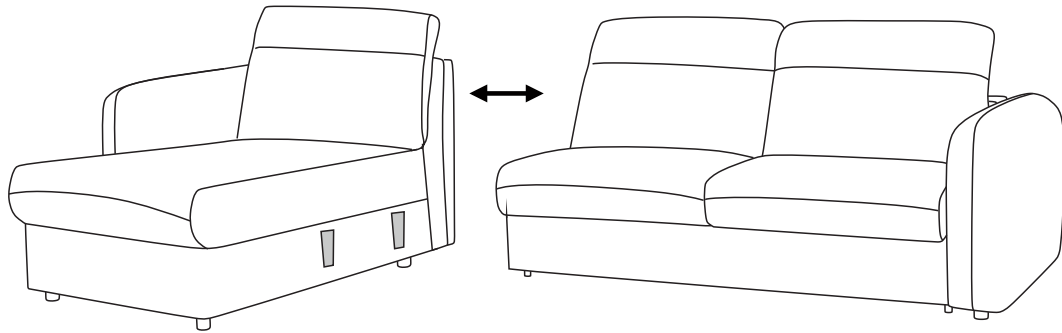

XI

D x 2

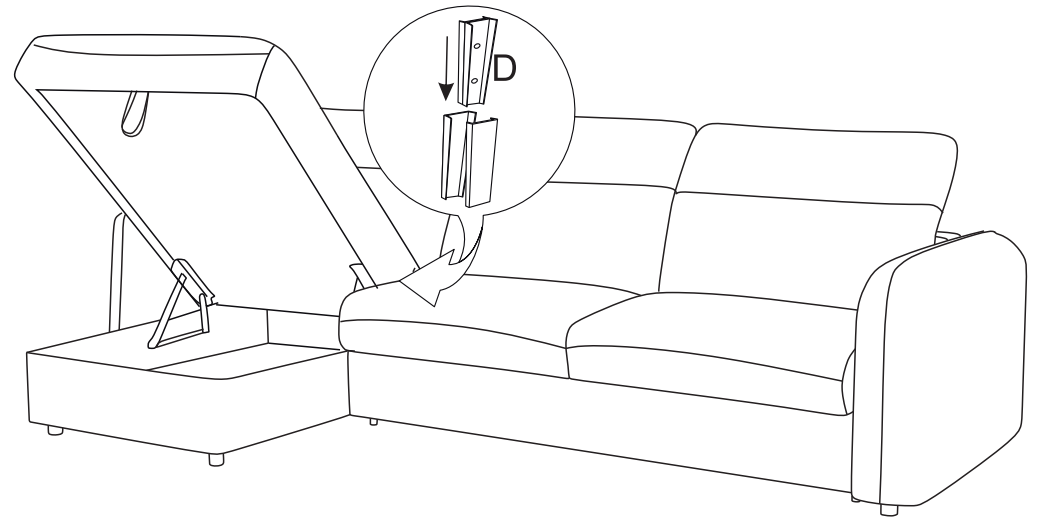

X

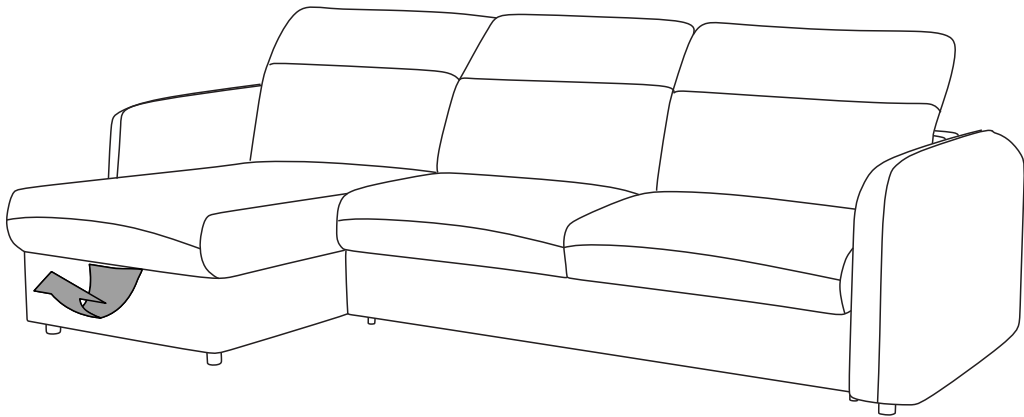

XII

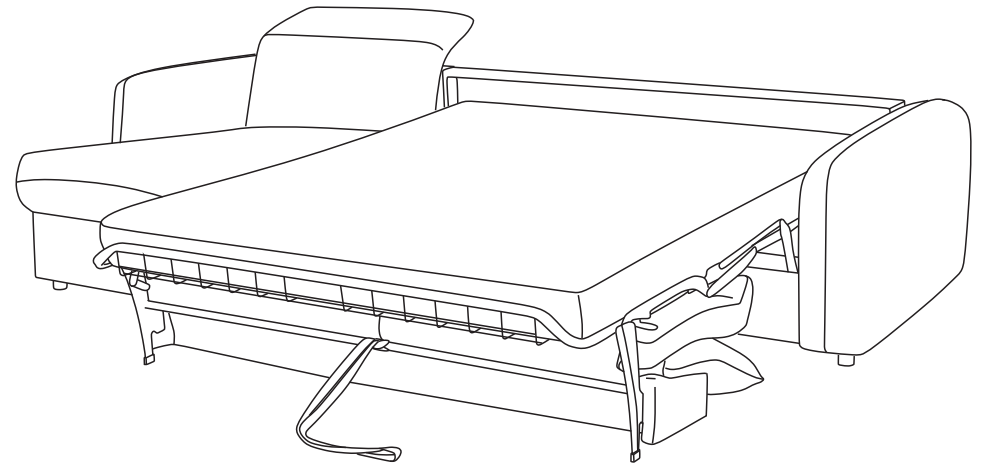

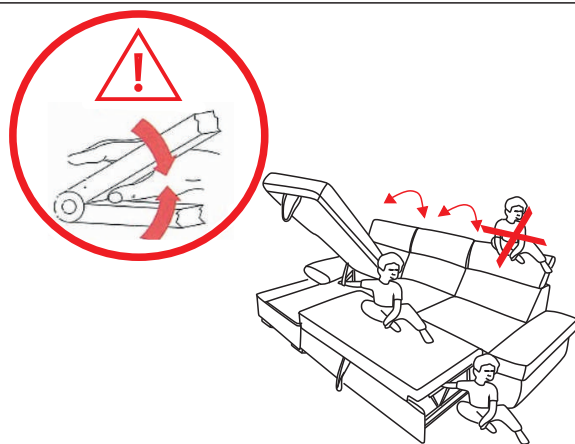
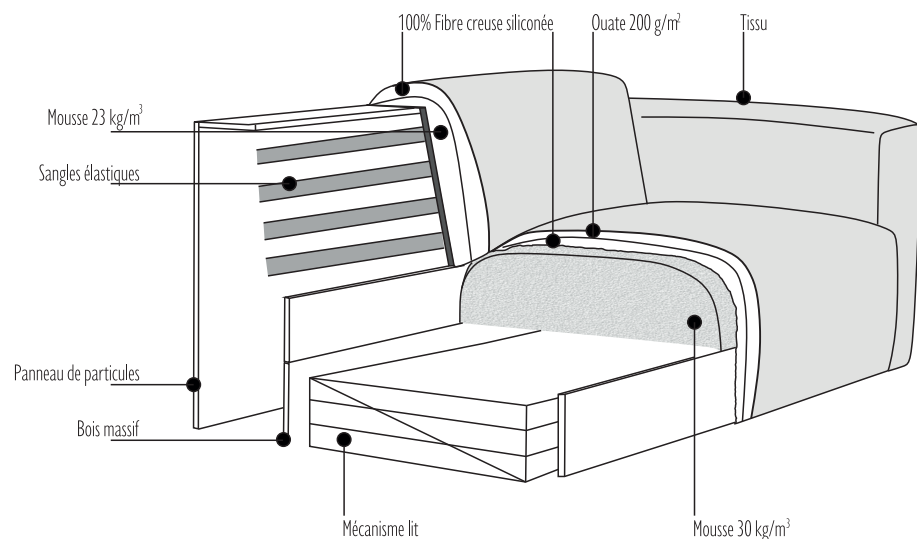
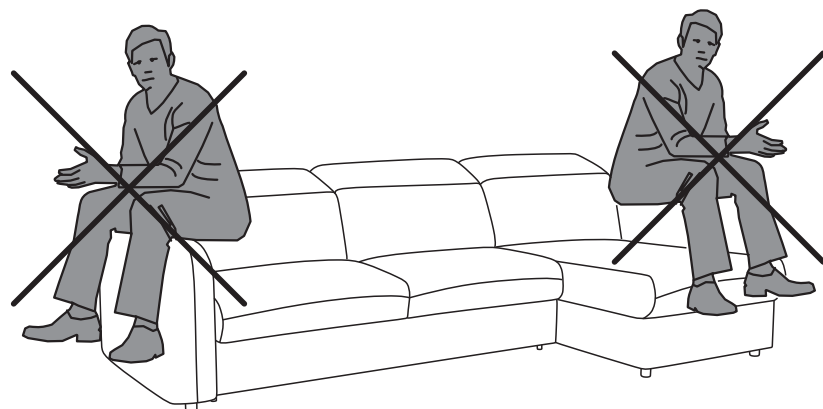

En raison du matériau utilisé dans la fabrication du mécanisme, un effet de grincement peut apparaître avec le temps.  
Le fabricant suggère d'utiliser un spray de préservation/entretien de l'acier.

Due to the material used in the manufacture of the mechanism, a creaking effect may appear over time.  
The manufacturer suggests using a steel preservation / maintenance spray.

Debido al material que se recrea para la producción, Después de un tiempo, puede producirse un efecto chirriante.  
Luego, el fabricante sugiere utilizar un lubricante/mantenimiento de acero.

Devido ao material utilizado para produzir o mecanismo, Depois de algum tempo, pode aparecer um efeito de rangido.  
O fabricante então sugere o uso de um lubrificante/manutenção de aço.

Aufgrund des verwendeten Materials zur Produktion von dem Mechanismus, kann nach einiger Zeit zum Knarrefekt kommen.  
Der Hersteller empfiehlt dann die Verwendung eines Stahlkonservierungs- / Schmiermittels.

A causa del materiale utilizzato per produrre il meccanismo, Dopo un po' di tempo potrebbe apparire un effetto scricchiolante.  
Il produttore suggerisce quindi di utilizzare un lubrificante/conservante per l'acciaio.

Remarque : les bosses, la déformation du siège, les concavités du coussin du siège ne sont pas un défaut et ne font pas l'objet d'une réclamation.  
Ce sont les caractéristiques des oreillers remplis de silicone et sont une caractéristique distinctive de ce produit.

Note: Dents, deformations of the seat, concavities of the seat are not a defect and are not subject to complaint.  
These are the characteristics of silicone-filled pillows and are the distinguishing features of this product.

Nota: Las abolladuras, deformaciones del asiento, concavidades del asiento no son un defecto y no son objeto de reclamación.  
Estas son las características de las almohadas rellenas de silicona y son los rasgos distintivos de este producto.

Nota: As massas, as deformações do assento, as concavidades do assento não constituem um defeito e não são objeto de reclamação.  
Estas são as características das almofadas com enchimento de silicone e são as características distintivas deste produto.

Hinweis: Dellen, Verformungen des Sitzes, Wölbungen des Sitzes sind kein Mangel und können nicht reklamiert werden.  
Dies sind die Eigenschaften von silikongefüllten Kissen und sind die Unterscheidungsmerkmale dieses Produkts.

Nota: Ammacature, deformazioni del sedile, concavità del sedile non sono un difetto e non sono soggette a reclamo.  
Queste sono le caratteristiche dei cuscini con imbottitura in silicone e sono le caratteristiche distintive di questo prodotto.

**Ne pas fermer le mécanisme avec des composants qui ne lui appartiennent pas.**

**Do not close the mechanism with components not belonging to it.**

**No cierre el mecanismo con componentes que no le pertenezcan.**

**Não fechar o mecanismo com componentes não pertencentes ao mesmo.**

**Schließen Sie den Mechanismus nicht mit Bauteilen, die nicht zu ihm gehören.**

**Non chiudere il meccanismo con componenti non appartenenti ad esso.**

Le boulochage du tissu est une caractéristique normale et ne peut pas être éliminé.  
Pour des raisons technologiques, les différences de nuances de couleurs sont acceptables.

Fabric pilling is a normal feature and cannot be eliminated.  
For technological reasons, differences in color shades are allowed.

El pilling de la tela es una característica normal y no se puede eliminar.  
Por razones tecnológicas, se permiten diferencias en los tonos de color.

O pilling do tecido é uma característica normal e não pode ser eliminado.  
Por razões tecnológicas, são permitidas diferenças de tonalidades de cores.

Pilling ist eine natürliche Eigenschaft des Stoffes und kann nicht ausgeschlossen werden.  
Unterschiede in den Farbtönen sind aus technischen Gründen zulässig.

Il pilling sui tessuti è una caratteristica normale e non può essere eliminata.  
Per ragioni tecnologiche sono ammesse differenze di tonalità di colore.

# All about MAINTENANCE POLICY

Thank you for choosing us, the mechanism you are using is one of the safest and most tested in the world and has been produced for over 20 years. Like any mechanical product, it is important to give it the right attention so that you can always use it at its best.

You can lubricate the sensitive points with any bicycle lubricant.  
Be careful not to use unlocking products, only lubricants.

It is important to lubricate and clean the joints between the pipes periodically, depending on the frequency of use. We recommend lubricating the central contact part.

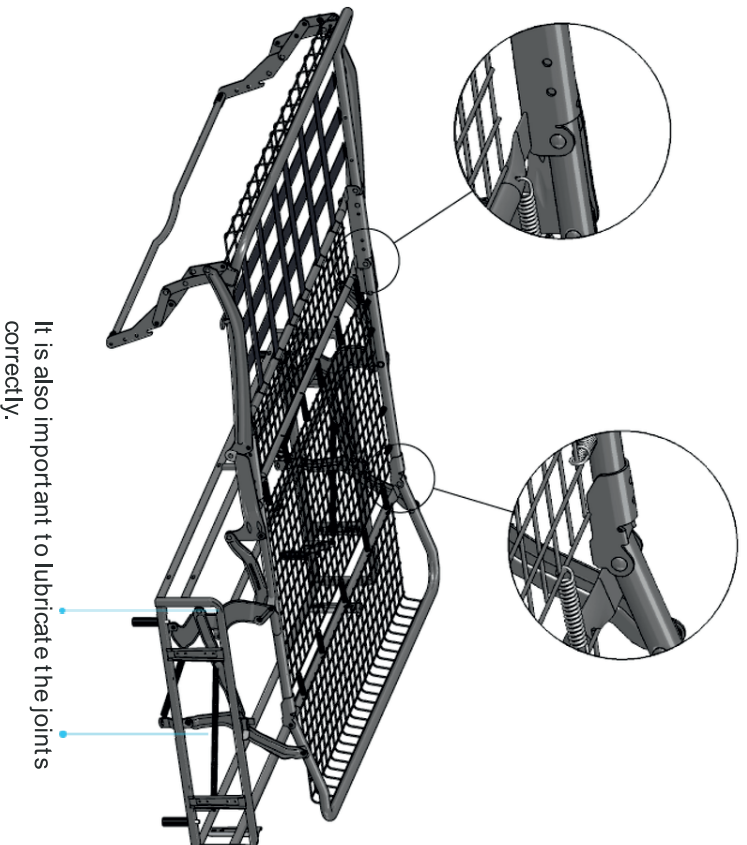

## Recommended operations

1. Remember to lubricate the mechanical joints periodically, as shown in the figure below, to ensure the best possible use and prevent noise creation.

2. It is advisable to use the mechanism as correctly as possible, they are durable if properly maintained.

## Not recommended operations

1. It is forbidden to dose objects that are not part of the mattress inside the mechanism, such as blankets or pillows, in order to avoid deformation.

2. This mechanism has been tested and developed for quality sleep any other action could impair its correct functioning

# Tout sur POLITIQUE DE MAINTENANCE

Merci de nous avoir choisis, le mécanisme que vous utilisez est l'un des plus sûrs et des plus testés au monde et est produit depuis plus de 20 ans. Comme tout produit mécanique, il est important de lui accorder l'attention nécessaire pour que vous puissiez toujours l'utiliser au mieux.

Vous pouvez lubrifier les points sensibles avec n'importe quel lubrifiant pour vélo.

Veillez ne pas utiliser de produits de déblocage, mais uniquement des lubrifiants.

Il est important de lubrifier et de nettoyer périodiquement les joints entre les tuyaux, en fonction de la fréquence d'utilisation. Nous recommandons de lubrifier la partie centrale de contact.

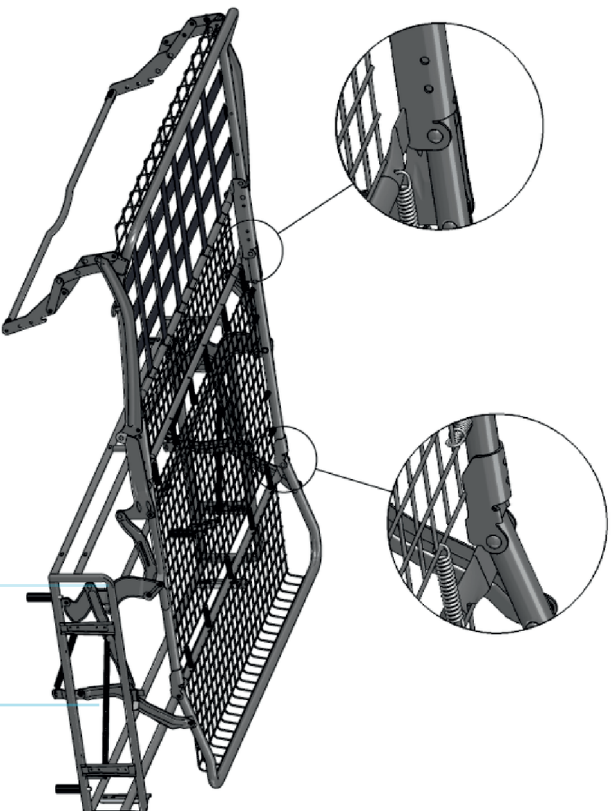

## Recommended operations

1. N'oubliez pas de lubrifier périodiquement les joints mécaniques, comme le montre la figure ci-dessous, pour garantir une utilisation optimale et éviter la création de bruit.  
Il est conseillé d'utiliser le mécanisme le plus correctement possible, ils sont durables s'ils sont correctement entretenus.
- 2.

## Not recommended operations

- Il est interdit d'enfermer des objets qui ne font pas partie du matériel à l'intérieur du mécanisme, tels que des couvertures ou des oreillers, afin d'éviter toute déformation.
1. Ce mécanisme a été testé et développé pour un sommet de qualité ; toute autre action pourrait nuire son bon fonctionnement.
  - 2.